

BEFORE THE ILLINOIS POLLUTION CONTROL BOARD

Vos Farms-Chadwick )  
(Property Identification Number ) PCB 012-  
03-05-200-002) (Tax Certification)  
)

NOTICE

Clerk  
Illinois Pollution Control Board  
James R. Thompson Center  
100 West Randolph Street, Suite. 11-500  
Chicago, Illinois 60601

Raymond Vos  
18917 Clark Road  
Chadwick, Illinois 61014

Steve Santarelli  
Illinois Department of Revenue  
101 West Jefferson  
Post Office Box 19033  
Springfield, Illinois 62794

PLEASE TAKE NOTICE that I have today filed with the Office of the Clerk of the Pollution Control Board an APPEARANCE AND THE RECOMMENDATION of the Illinois Environmental Protection Agency, a copy of which is herewith served upon you.

ENVIRONMENTAL PROTECTION AGENCY  
OF THE STATE OF ILLINOIS

By: Vera Herst  
Vera Herst  
Assistant Counsel  
Division of Legal Counsel

DATED: August 15, 2011

Illinois Environmental Protection Agency  
1021 North Grand Avenue East  
Post Office Box 19276  
Springfield, Illinois 62794-9276  
(217) 782-5544

THIS FILING IS SUBMITTED ON RECYCLED PAPER

BEFORE THE ILLINOIS POLLUTION CONTROL BOARD

Vos Farms-Chadwick )  
(Property Identification Number ) PCB 012-  
03-05-200-002) (Tax Certification)  
)

A P P E A R A N C E

The undersigned, as one of its attorneys, hereby enters an APPEARANCE on behalf of Respondent,  
Illinois Environmental Protection Agency.

ILLINOIS ENVIRONMENTAL PROTECTION AGENCY

By: Vera Herst  
Vera Herst  
Assistant Counsel  
Division of Legal Counsel

DATED: August 15, 2011  
Illinois Environmental Protection Agency  
1021 North Grand Avenue East  
Post Office Box 19276  
Springfield, Illinois 62794-9276  
(217)782-5544

THIS FILING IS SUBMITTED ON RECYCLED PAPER

**BEFORE THE ILLINOIS POLLUTION CONTROL BOARD**

Vos Farms-Chadwick )  
(Property Identification Number ) PCB 012-  
03-05-200-002) (Tax Certification)  
)

**RECOMMENDATION**

The Illinois Environmental Protection Agency ("Illinois EPA") hereby files its Recommendation pursuant to Section 125.204 of the regulations of the Illinois Pollution Control Board, 35 Ill. Adm. Code 125.204.

1. On November 8, 2010, the Illinois EPA received a request from Vos Farms (log number TC-15-10, Exhibit A) for an Illinois EPA recommendation regarding the tax certification of water pollution control facilities pursuant to 35 Ill. Adm. Code 125.204.
2. The applicant's address is: Vos Farms  
18917 Clark Road  
Chadwick, Illinois 61014
3. The proposed water pollution control facilities in this request are located at NE 1/4 Section 5, T22N, R5E of the 4th PM in Whiteside County, at the above street address and consist of the following:  

Livestock waste management facilities consisting of one concrete a manure pit (approximately 44ft. x 288 ft. x 10 ft.) and the portion of concrete slabbing over the manure pit in building #1.

These livestock waste management facilities are used to collect, transport and/or store livestock wastes prior to cropland application, and are further described in Exhibit A.
4. Section 11-10 of the Property Tax Code, 35 ILCS 200/11-10 (2010), defines "pollution control facilities" as:

**THIS FILING IS SUBMITTED ON RECYCLED PAPER**

“any system, method, construction, device or appliance appurtenant thereto or any portion of any building or equipment, that is designed, constructed, installed or operated for the primary purpose of: (a) eliminating, preventing, or reducing air or water pollution ...or (b) treating, pretreating, modifying or disposing of any potential solid, liquid or gaseous pollutant which if released without treatment, pretreatment modification or disposal might be harmful, detrimental or offensive to human, plant or animal life, or to property.”

5. Pollution control facilities are entitled to preferential tax treatment, 35 ILCS 200/11-5.
  
6. Based on the information in the application and the purpose of the facilities, it is the Illinois EPA’s engineering judgment that the described facilities may be considered “pollution control facilities,” pursuant to 35 Ill. Adm. Code 125.200(a), with the primary purpose of eliminating, preventing, or reducing water pollution, or as otherwise provided in 35 Ill. Adm. Code 125.200, and are eligible for tax certification from the Board.

WHEREFORE, the Illinois EPA recommends that the Board issue the

requested tax certification.

ILLINOIS ENVIRONMENTAL  
PROTECTION AGENCY

By:   
Vera Herst  
Assistant Counsel  
Division of Legal Counsel

Dated: August 15, 2011  
Illinois Environmental Protection Agency  
1021 North Grand Ave. E.  
P.O. Box 19276  
Springfield, Illinois 62794-9276  
217/782-5544



ILLINOIS ENVIRONMENTAL PROTECTION AGENCY

1021 North Grand Avenue East, P.O. Box 19276, Springfield, Illinois 62794-9276 • (217) 782-2829  
James R. Thompson Center, 100 West Randolph, Suite 11-300, Chicago, IL 60601 • (312) 814-6026

PAT QUINN, GOVERNOR

DOUGLAS P. SCOTT, DIRECTOR

Memorandum

To: Connie Tonsor, Division of Legal Counsel

From: Al Keller, Manager, Permit Section

*Al Keller by D.H. Keavel*

Date: August 1, 2011

Re: Vos Farms - Chadwick  
Recommendation of Tax Certification  
Log # TC-15-10  
Property Identification # 03-05-200-002

RECEIVED  
Division of Legal Counsel  
AUG 12 2011  
Environmental Protection Agency

The Bureau of Water received a request on November 8, 2010 from Vos Farms for an Illinois EPA recommendation regarding the tax certification of water pollution control facilities pursuant to 35 Il. Adm. Code 125.204. We offer the following recommendation.

The water pollution control facilities in this request include the following:

Vos Farms  
18917 Clark Road  
Chadwick, IL 61014

NE 1/4 Section 5, Township 22N, Range 5E of the 4th PM in Whiteside County.

Livestock waste management facilities consisting of one concrete manure pit approximately (44 ft. x 288 ft. x 10 ft. deep) and the portion of concrete slat flooring over the manure pit in building #1.

These livestock waste management facilities are used to collect, transport and/or store livestock wastes prior to cropland application.

These facilities are further described in the enclosed applications and supporting documents.

Based on the information included in this submittal, it is our engineering judgment that the above proposed facilities may be considered "Pollution Control Facilities" under 35 IAC 125.200(a), with the primary purpose of eliminating, preventing, or reducing water pollution, or as otherwise provided in this section, and therefore eligible for tax certification from the Illinois Pollution Control Board. The Bureau of Water therefore recommends that the Board issue the requested tax certification for these facilities.

If you have any questions regarding the above, please contact Darren Gove at 217/782-0610.

SAK:DRG:TC-15-10\_Tax Cert Recommendation\_08Nov10.docx

cc: Tax Cert File

DRG

Watershed Unit Tax Certification Review Sheet

Project Name: Vos Farms

Location: Chadwick

Reviewer: DRG

Date: June 21, 2011

Log number: TC-15-10

Type:  Agchem

Livestock

Applicant: Vos Farms  
18917 Clark Road  
Chadwick, IL 61014

Contact: \_ Raymond Vos

Phone: \_ 815-684-5634

Facility: Vos Farms  
18917 Clark Road  
Chadwick, IL 61014

Property ID: 03-05-200-002

County: Whiteside

Legal Description:

S: NE 1/4 Section 5 Twp: 22N R: 5E PM: 4th

Signature: Raymond Vos

Title: Owner

Date Control Devices installed: 10/10/2009

Provided Fair cash Value: \$204,922

Wastes:  Livestock waste is applied to cropland.  
 Agrichemical rinsate and spillage is recycled through the facility and/or land applied.  
 Other: \_\_\_\_\_

Physical Description of Pollution Control Devices:

Livestock waste management facilities consisting of one concrete manure pit approximately (44 ft. x 288 ft. x 10 ft. deep) and the portion of concrete slat flooring over the manure pit in building #1.

These livestock waste management facilities are used to collect, transport and/or store livestock wastes prior to cropland application.

[6/13/2011 : Ray voss returned call - informed me that had no pump out pits and entire pit covered with slat flooring, nothing else to certify]-[6/7/2011 : called and left message]-[ 11/22/10 Logged in]

APPLICATION FOR CERTIFICATION (PROPERTY TAX TREATMENT)  
 POLLUTION CONTROL FACILITY  
 AIR  WATER

This Agency is authorized to request this information under Illinois Revised Statutes, 1979, Chapter, 120, Section 502a-5. Disclosure of this information is voluntary. However, failure to comply could prevent your application from being processed or could result in denial of your application for certification.

ILLINOIS ENVIRONMENTAL PROTECTION AGENCY  
 P. O. Box 19276, Springfield, IL 62794-9276

FOR AGENCY USE

File No.	Date Received	Certification No.	Date	
Sec. A  APPLICANT	Company Name UOS FARMS			
	Person Authorized to Receive Certification RAYMONA C. UOS		Person to Contact for Additional Details RAYMONA C. UOS	
	Street Address 18917 CLARK RD		Street Address 18917 CLARK RD.	
	Municipality, State & Zip Code CHADWICK, IL 61014		Municipality, State & Zip Code CHADWICK, IL 61014	
	Telephone Number 815-684-5634		Telephone Number 815-684-5634	
	Location of Facility Quarter Section Township Range NE SECTION 5 22 NORTH 5 EAST		Municipality Township CLYDE - 22	
	Street Address 18917 CLARK RD		County Book Number WHITESIDE	
	Property Identification Number 03-05-200-002		Parcel Number 03-05-200-002	
	Sec. B  MANUFACTURING OPERATIONS	Nature of Operations Conducted at the Above Location FEEDLOT CATTLE ARE FED IN A BUILDING OVER A SLOTTED FLOOR WHICH MEASURES 44' x 288' x 10'. MANURE IS COLLECTED AND STORED IN THE PIT AND INJECTED IN THE SOIL FOR USE BY CROPS EVERY 6 MONTHS.		
Water Pollution Control Construction Permit No. ILR10K702		Date Issued 10-8-2008		
NPDES PERMIT No.		Date Issued		
Air Pollution Control Construction Permit No.		Date Issued		
Air Pollution Control Operating Permit No.		Date Issued		
Sec. C  MANUFACTURING PROCESS	Describe Unit Process			
	Materials Used in Process			<p style="text-align: center;"><b>RECEIVED</b> NOV - 8 2010</p> <p style="text-align: center;">Watershed Management Section BUREAU OF WATER</p>
Sec. D  POLLUTION CONTROL FACILITY DESCRIPTION	Describe Pollution Abatement Control Facility MANURE PIT IS MADE OF CONCRETE AND STEEL. THE PIT IS COVERED BY SLATS THAT ARE MADE OF CONCRETE AND STEEL. THERE ARE NO PERMANENT PUMPS, PIPES, OR SCRAPERS. ALL MANURE IS CONTAINED IN THE 44' x 288' x 10' PIT.			



FAIR HAVEN  
UNITED METHODIST CHURCH  
6,300'

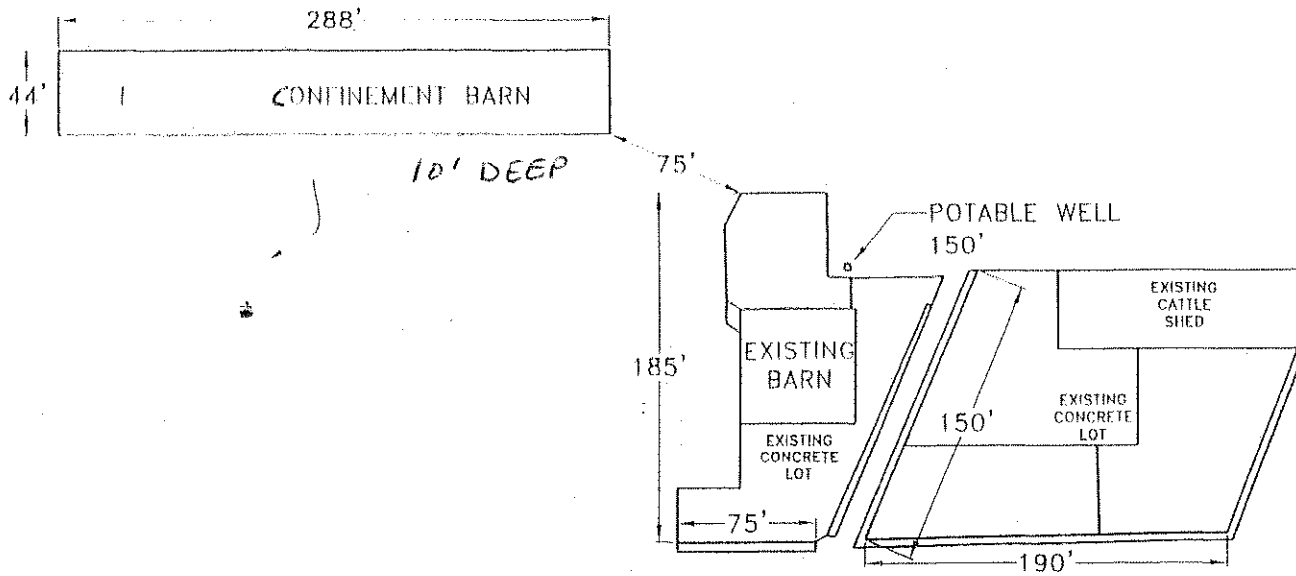

ADOLPH TRUCKING  
8,400'

LITTLE ROCK CREEK  
2,600'

JEFF CHELSTRUM  
3,500'

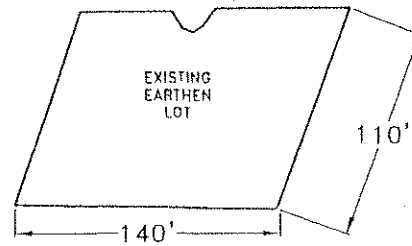

- NOTES:
- \*CLOSEST TOWN IS COLETA
  - \*CLOSEST NEIGHBOR IS JEFF CHELSTRUM
  - \*CLOSEST NFB IS ADOLPH TRUCKING
  - \*CLOSEST CPOA IS FAIR HAVEN UNITED METHODIST CHURCH
  - \*CLOSEST STREAM IS LITTLE ROCK CREEK
  - \*NO ABANDONED WELLS WITHIN 1,000'
  - \*NO SUBSURFACE DRAINAGE LINES WITHIN 100'

↑  
SURFACE WATER FLOW DIRECTION

COLETA  
36,900'

100'

STATE OF ILLINOIS

COUNTY OF SANGAMON

)  
)  
)  
)  
)

**PROOF OF SERVICE**

I, the undersigned attorney at law, hereby certify that on August 15, 2011, I served true and correct copies of an APPEARANCE AND THE RECOMMENDATION, upon the persons and by the methods as follows:

[1<sup>st</sup> Class U.S. Mail]

Steve Santarelli  
Illinois Department of Revenue  
101 West Jefferson  
Post Office Box 19033  
Springfield, Illinois 62794

[1<sup>st</sup> Class U.S. Mail]

Raymond Vos  
18917 Clark Road  
Chadwick, Illinois 61014

[Electronic Filing]

Clerk  
Illinois Pollution Control Board  
James R. Thompson Center  
100 West Randolph Street, Suite. 11-500  
Chicago, Illinois 60601

ILLINOIS ENVIRONMENTAL PROTECTION AGENCY

/s/ Vera Herst  
Assistant Counsel  
Division of Legal Counsel  
1021 North Grand Avenue East  
P.O. Box 19276-  
Springfield, Illinois 62794-9276  
217.782.5544  
217.782.9143 (TDD)

**THIS FILING IS SUBMITTED ON RECYCLED PAPER**